



AST-V2315NVF

Vandal-Resistant Dome Camera



Features

- 1/3 inch Sony Super HAD CCD
- High Resolution : 550 TV Lines
- Built-in DC Iris Vari-focal Lens(f=3.8~9.5mm)
- **Day&Night (ICR)**
- Auto White Balance
- AGC, BLC, Flickerless (On/Off)
- Min. Illumination : Night (0.1 Lux, ICR)
- Extra Video Out Port for Installer
- 3-Axis Camera Construction
- Built-in Heater (Option), Camera Bracket (Option)
- Flush or Surface Mount
- AC24V / DC12V Dual Voltage
- Dome Size : 100mm



DIMENSIONS

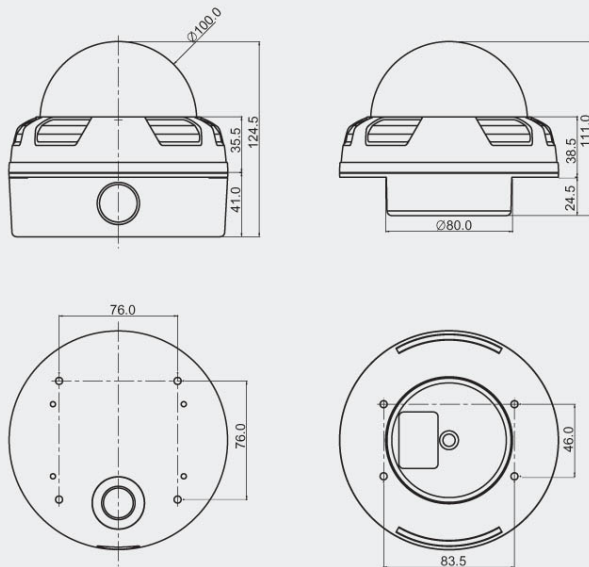

SPECIFICATIONS

Model	AST-V2315NVF
Signal System	NTSC
Scanning System	2:1 Interlace
Scanning Frequency (H)	15.734 KHz
Scanning Frequency (V)	59.94 Hz
Image Sensor	1/3 Inch SONY Super HAD CCD
Total Pixels	811(H) x 508(V) 410K
Total / Effective Pixels	768(H) x 494(V) 380K
Horizontal Resolution	550 TV Lines
Video Output	1.0V p-p (75Ω, Composite)
S/N Ratio	More than 50dB(AGC Off)
Lens	DC Iris Vari-focal Lens (f=3.8~9.5mm)
Min.Illumination	Day (0.3 Lux), Night(0.1 Lux, ICR)
Day&Night (ICR)	On/Off (Dip Switch)
UTP	No
White Balance	Auto
AGC,BLC,Flickerless	On/Off (Dip Switch)
Shutter Speed	1/60~1/100,000 Sec.
Supplied Voltage	AC 24v (20V~28V) or DC 12V (10V~15V)
Power Consumption	Max 5W
Heater (Option)	Operation Temperature : Under 10 ° F
Dimensions(ØxH)	Surface : 100.0 x 124.5 mm Flush : 100.0 x 111.0 mm
Weight	Approx. 1210g