



# AST-SD1700N

## SMOKE DETECTOR TYPE DOME CAMERA



### Features

- 1/3 inch Sony Super HAD CCD
- Built-in Fixed Lens (f=3.8mm)
- Auto White Balance
- AGC, BLC (On/Off)
- Min. Illumination : 0.1 Lux



### DIMENSIONS

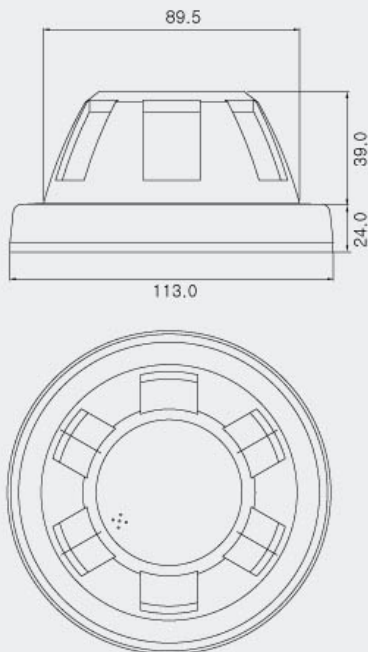

### SPECIFICATIONS

Model	AST-SD1700N
Signal System	NTSC
Scanning System	2:1 Interlace
Scanning Frequency (H)	15.734 kHz
Scanning Frequency (V)	59.94 kHz
Image Sensor	1/3 Inch SONY Super HAD CCD
Total Pixels No.	537 (H) x 505 (V) x 270K
Effective Pixels	510 (H) x 492 (V) x 250K
Horizontal Resolution	380 TV Lines
Video Output	Composite: 1.0V p-p, 75Ω
S/N Ratio	More than 48dB(AGC Off)
Lens	Fixed Lens (f=3.8mm)
Min.Illumination	0.1 Lux
White Balance	Auto
AGC/BLC	On/Off (DIP Switch)
Shutter Speed	1/60~1/10,000 sec.
Supplied Voltage	DC 9V~15V (Recommendation DC±0.5V))
Power Consumption	Less than 150mA
Dimensions(ØxH)	89.5 x 63 mm
Weight	Approx. 157g