

## AST-BE4815NVR

## Weather Proof IR Camera



### Features

- 1/3 inch SONY Super HAD CCD
- High Resolution : 550TV Lines
- DC Iris Varifocal lens (f=3.8~9.5m F1.2)
- **Built-in IR LED (56EA) & Sensor(1EA)**
- True Day&Night (ICR)
- **SDNR(Super Digital Noise Reduction)**
- Electronic sensitivity-up (DSS)
- Auto White Balance
- AGC/BLC/Flickerless (On/Off)
- Min : Day(0.3Lux), Night(0.00Lux,IR LED On)
- Extra Video Out Port for Installer
- Weather-proof Housing
- AC24V/DC12V Dual Voltage
- Built in Fan/Heater



### DIMENSIONS

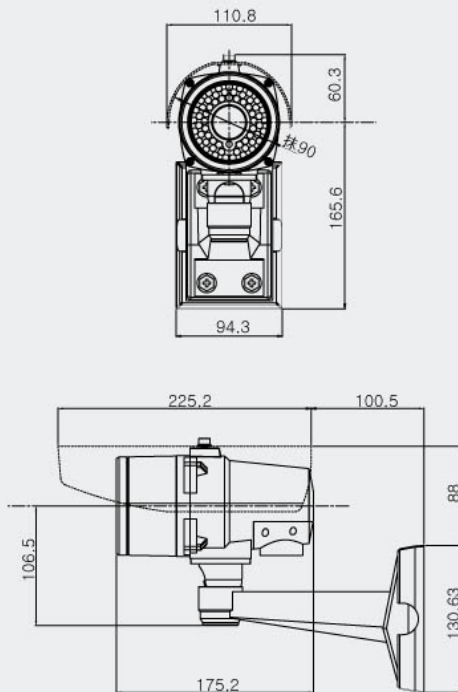

### SPECIFICATIONS

| Model                    | AST-BE4815NVR                                   |
|--------------------------|---|
| Signal System            | NTSC  |
| Scanning System          | 2:1 Interlace                                   |
| Scanning Frequency (H)   | 15.734 KHz                                      |
| Scanning Frequency (V)   | 59.94 Hz  |
| Image Sensor             | 1/3 Inch SONY Super HAD CCD                     |
| Total Pixels             | 811(H) x 508(V) 410K                            |
| Total / Effective Pixels | 768(H) x 494(V) 380K                            |
| Horizontal Resolution    | 550 TV Lines                                    |
| Video Output             | 1.0V p-p (75Ω, Composite)                       |
| S/N Ratio                | More than 50dB(AGC Off)                         |
| Lens                     | DC Iris Varifocal Lens (f=3.8~9.5mm F1.2)       |
| Digital Zoom Ratio       | 2x (On/Off)                                     |
| Min.Illumination         | Day (0.3Lux), Night(0.00Lux, IR LED On)         |
| IR LED and Sensor        | IR LED 56EA (850nm, 15', 30' Mixed), Sensor 1EA |
| IR LED Visible Range     | Max. 50m  |
| Day&Night (ICR)          | ICR (Sensor Type)                               |
| DSS                      | On/Off (Max. 32FLD)                             |
| White Balance            | Auto  |
| AGC,BLC, Flickerless     | On/Off  |
| IP Rating                | IP65  |
| Supplied Voltage         | AC 24V or DC 12V Dual Voltage                   |
| Dimensions(WxHxD)        | 110.8 x 218.6 x 325.7 mm                        |
| Weight                   | Approx. 1.6kg                                   |